

DRY-WELL SEWAGE LIFTING STATION MODULE TYPE: ESS 150/2/2.6/1700 M



Technical parameters:

- Min. sump diameter $\varnothing 2600$ mm
- Retention module Steel 1.4307
- Active retention volume 1700 dm³
- Max inflow $Q_{max} = 100$ m³/h
- Piping diameter DN150
- Inflow connection diameter DN315
- Module weight 1200 kg (*)

(*) - without pumps

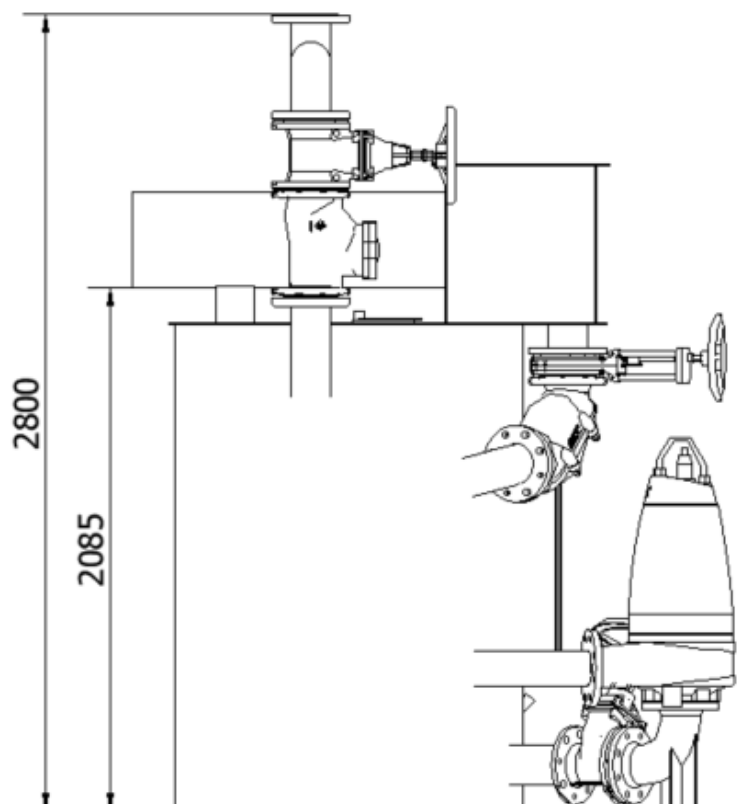
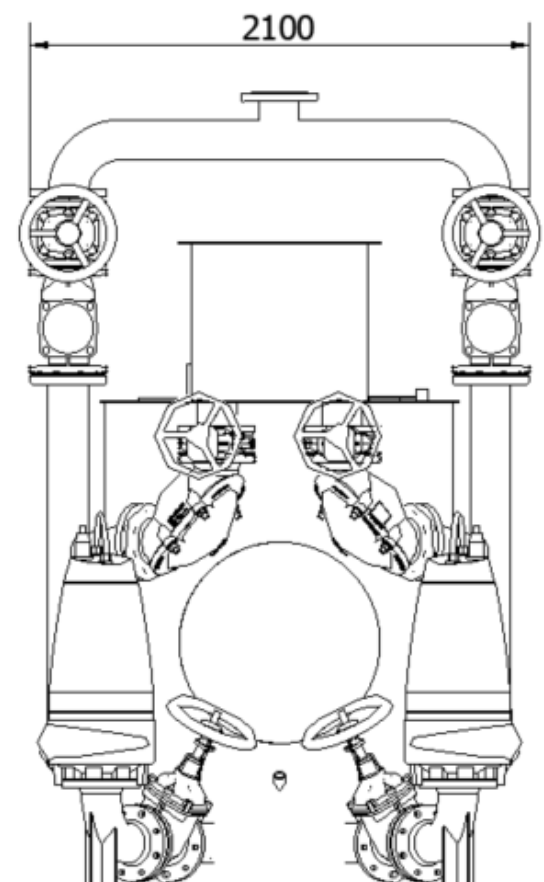
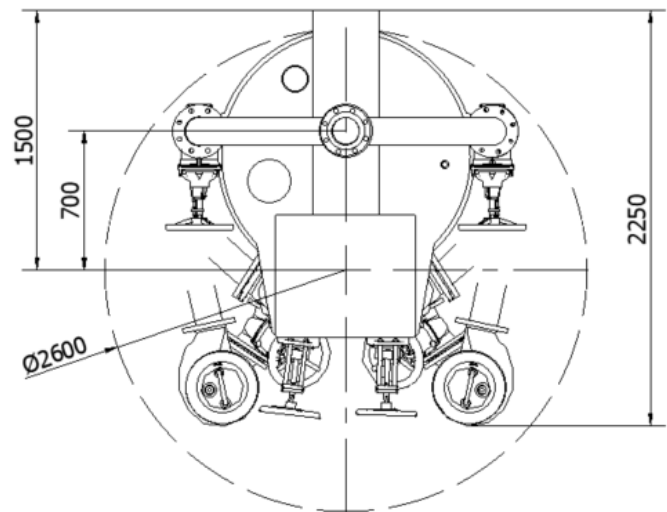

DRY-WELL SEWAGE LIFTING STATION MODULE TYPE: ESS 150/2/2.6/1700 M

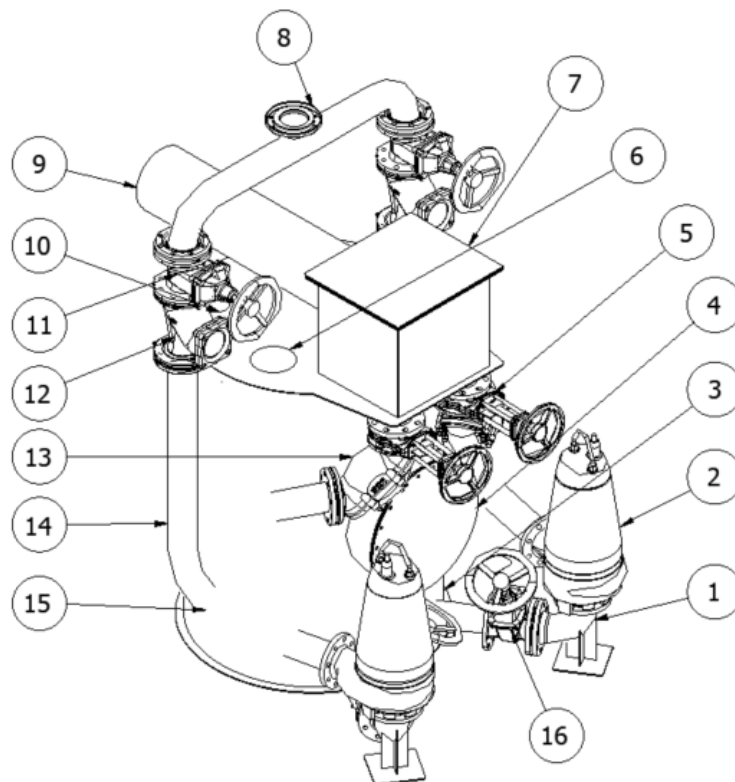

No.	Name	Qty	Material
1	Pump mounting elbow	2	Cast iron/St. steel 1.4307
2	Pump (**)	2	Cast iron
3	Retention tank	1	Steel 1.4307
4	Inspection hatch for the retention tank	1	Steel 1.4307
5	Knife gate valve on inflow DN150	2	Cast iron
6	Hydrostatic probe mount with cable gland	1	Steel 1.4307
7	Manifold with overflow system	1	Steel 1.4307/HDPE
8	DN150 module flange connection	1	Steel 1.4307
9	Connection pipe for gravity flow - pipe terminated with a flange connection 350 mm downstream of the manifold	1	Steel 1.4307
10	Ventilation of the lifting station module	1	Steel 1.4307
11	Soft-sealed gate valve on the discharge pipe	2	Cast iron
12	Straight ball check valve on the discharge pipe	2	Cast iron
13	Automatic shut-off of the inflow	2	Cast iron
14	Piping DN150	2	St. steel 1.4307
15	Solids separator with by-pass system	2	St. steel 1.4307
16	Knife gate valve	2	Cast iron

(**) - pumps not included in the standard scope of delivery