

DRY-WELL SEWAGE LIFTING STATION MODULE TYPE: ESS PE 150/2/2.6/1700 M



Technical parameters:

- Min. sump diameter $\varnothing 2600\text{mm}$
- HDPE retention module
- Active retention volume 1700 dm³
- Max inflow $Q_{\text{max}} = 100\text{m}^3/\text{h}$
- Piping diameter DN150
- Inflow connection diameter DN300
- Module weight 1050 kg (*)

(*) - without pumps

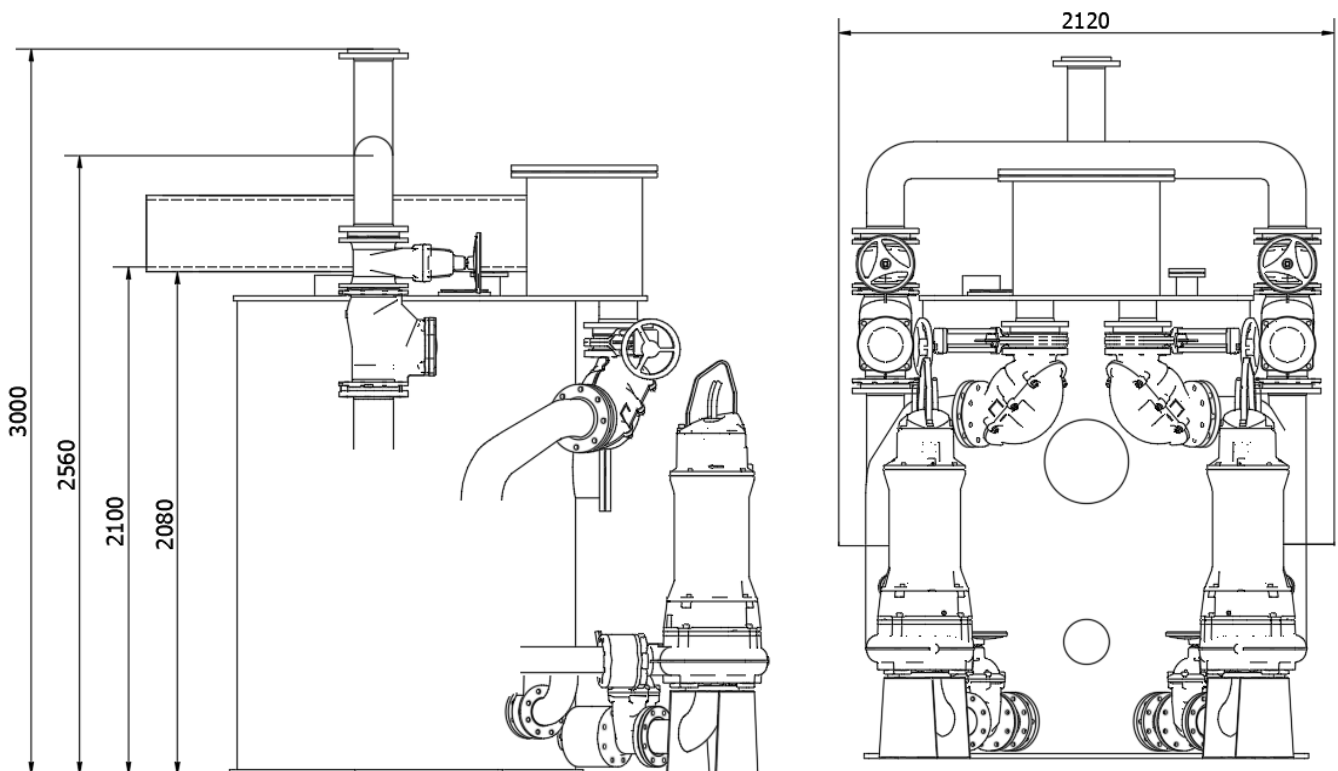
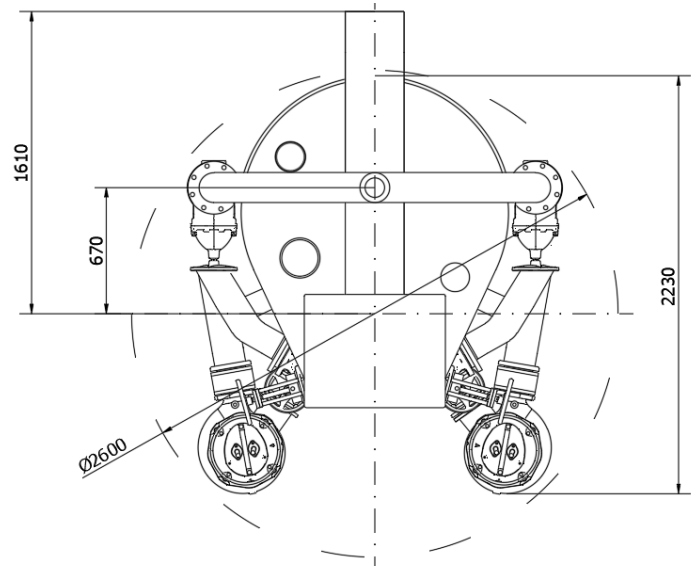

DRY-WELL SEWAGE LIFTING STATION MODULE TYPE: ESS PE 150/2/2.6/1700 M

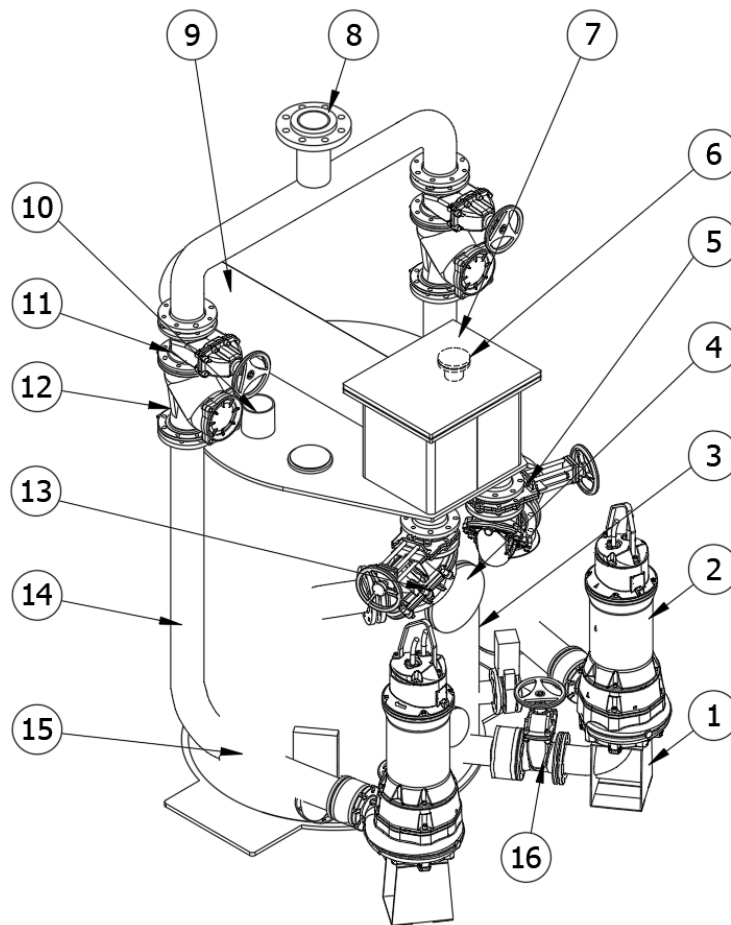

No.	Name	Qty	Material
1	Pump mounting elbow	2	Cast iron/ st. steel 1.4307
2	Pump	2	Cast iron
3	Retention tank	1	HDPE
4	Inspection hatch for the retention tank	1	HDPE
5	Knife gate valve on inflow DN150	2	Cast iron
6	Hydrostatic probe mount with cable gland	1	HDPE
7	Manifold with overflow system	1	HDPE
8	DN150 module flange connection	1	HDPE/PP
9	Connection pipe for gravity flow (**)	1	HDPE DN315
10	Ventilation of the lifting station module	1	DN150 (HDPE 160)
11	Soft-sealed gate valve on the discharge pipe	2	Cast iron DN150
12	Straight ball check valve on the discharge pipe	2	Cast iron DN150
13	Automatic shut-off of the inflow	2	Cast iron DN150
14	Piping DN150 (PE160/stainless steel DN150)	2	HDPE/st. steel 1.4307
15	Solids separator	2	St. steel 1.4307
16	Soft-sealed gate valve	2	Cast iron
17	By-pass system	2	HDPE/st. steel 1.4307/cast iron

(**) - pipe terminated with a flange connection 350 mm downstream of the manifold