

DRY-WELL SEWAGE LIFTING STATION MODULE TYPE: ETS II 80/2/1.6/300 M



Technical parameters:

- Sump diameter $\varnothing 2000$ mm
- Retention module Steel 1.4307
- Active retention volume 300 dm^3
- Max inflow $Q_{\text{max}} = 15 \text{ m}^3/\text{h}$
- Piping diameter DN80
- Inflow connection diameter DN200
- Module weight 800 kg (*)

(*) - without pumps

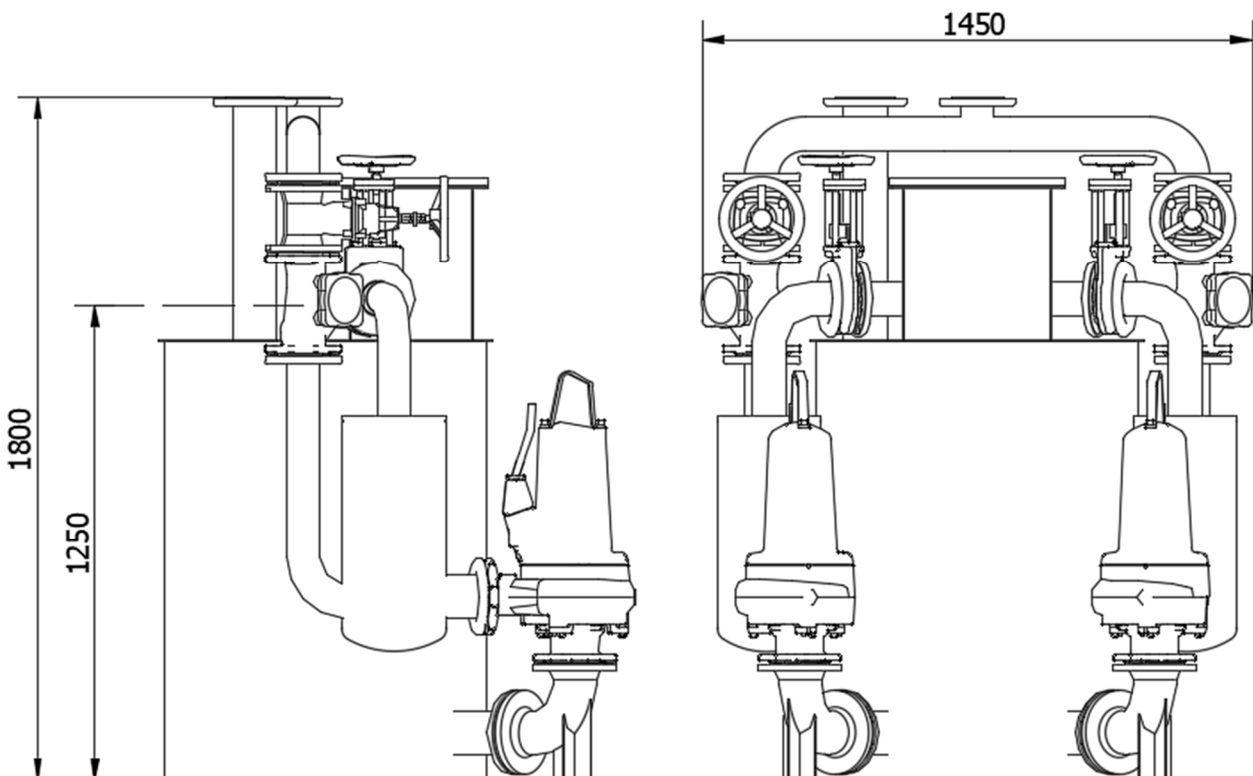
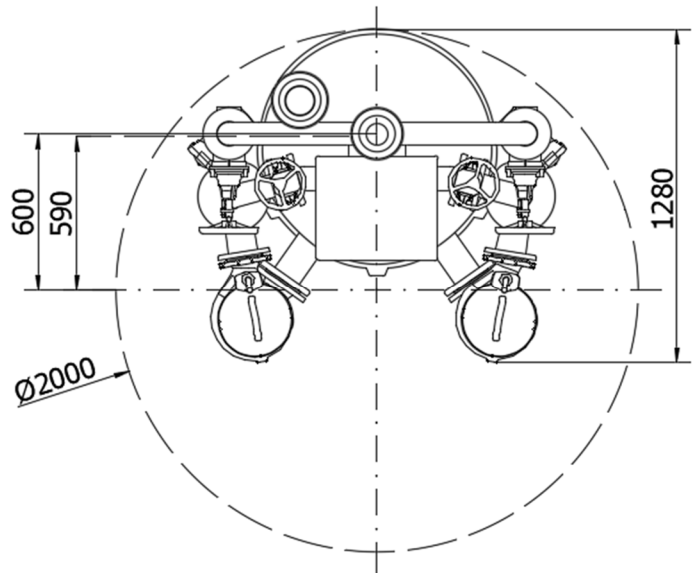

DRY-WELL SEWAGE LIFTING STATION MODULE TYPE: ETS II 80/2/1.6/300 M

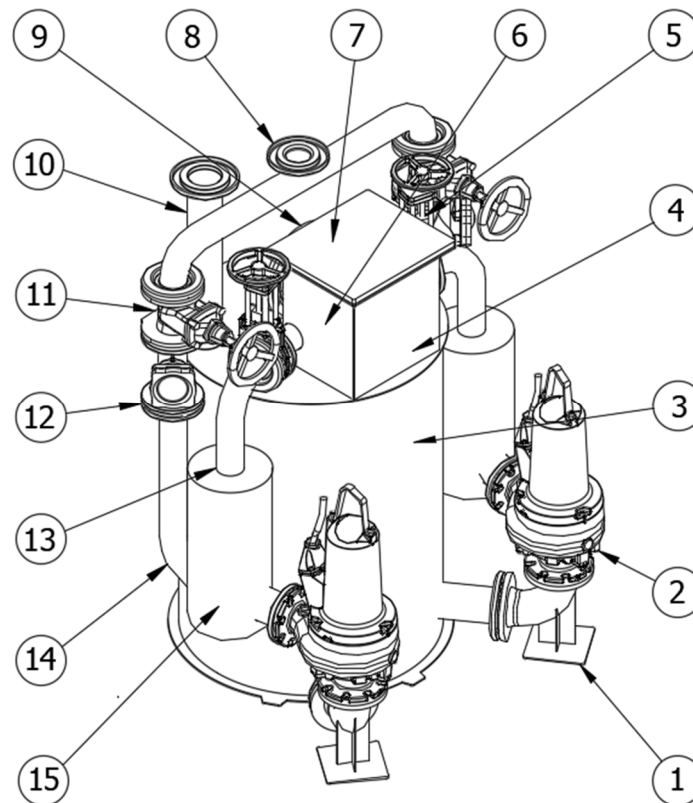

No.	Name	Qty	Material
1	Pump mounting elbow	2	Cast iron/St. steel 1.4307
2	Pump	2	Cast iron
3	Retention tank	1	Steel 1.4307
4	Hydrostatic probe mount with cable gland	1	Steel 1.4307
5	Knife gate valve on inflow DN80	2	Cast iron
6	Manifold with overflow system	1	Steel 1.4307/HDPE
7	Inspection hatch for the retention tank	1	Steel 1.4307
8	Module flange connection DN80	1	Steel 1.4307
9	Flange connection for gravity flow DN200	1	Steel 1.4307
10	Ventilation of the lifting station module DN100	1	Steel 1.4307
11	Soft-sealed gate valve on the discharge pipe DN80	2	Cast iron
12	Straight ball check valve on the discharge pipe DN80	2	Cast iron
13	Automatic shut-off of the inflow DN80	2	Cast iron
14	Piping DN80	2	St. steel 1.4307
15	Solids separator	2	St. steel 1.4307

(**) - pumps not included in the standard scope of delivery