

DRY-WELL SEWAGE LIFTING STATION

TYPE: ETS II PE 80/2/1.6/300/P/1600PE



Technical parameters:

- Sump diameter $\varnothing 1600\text{mm}$
- HDPE retention module
- Active retention volume 300 dm^3
- Max inflow $Q_{\text{max}} = 15\text{m}^3/\text{h}$
- Piping diameter DN80
- Inflow connection diameter DN200
- Transport height 2190 mm
- Transport width 2200 mm

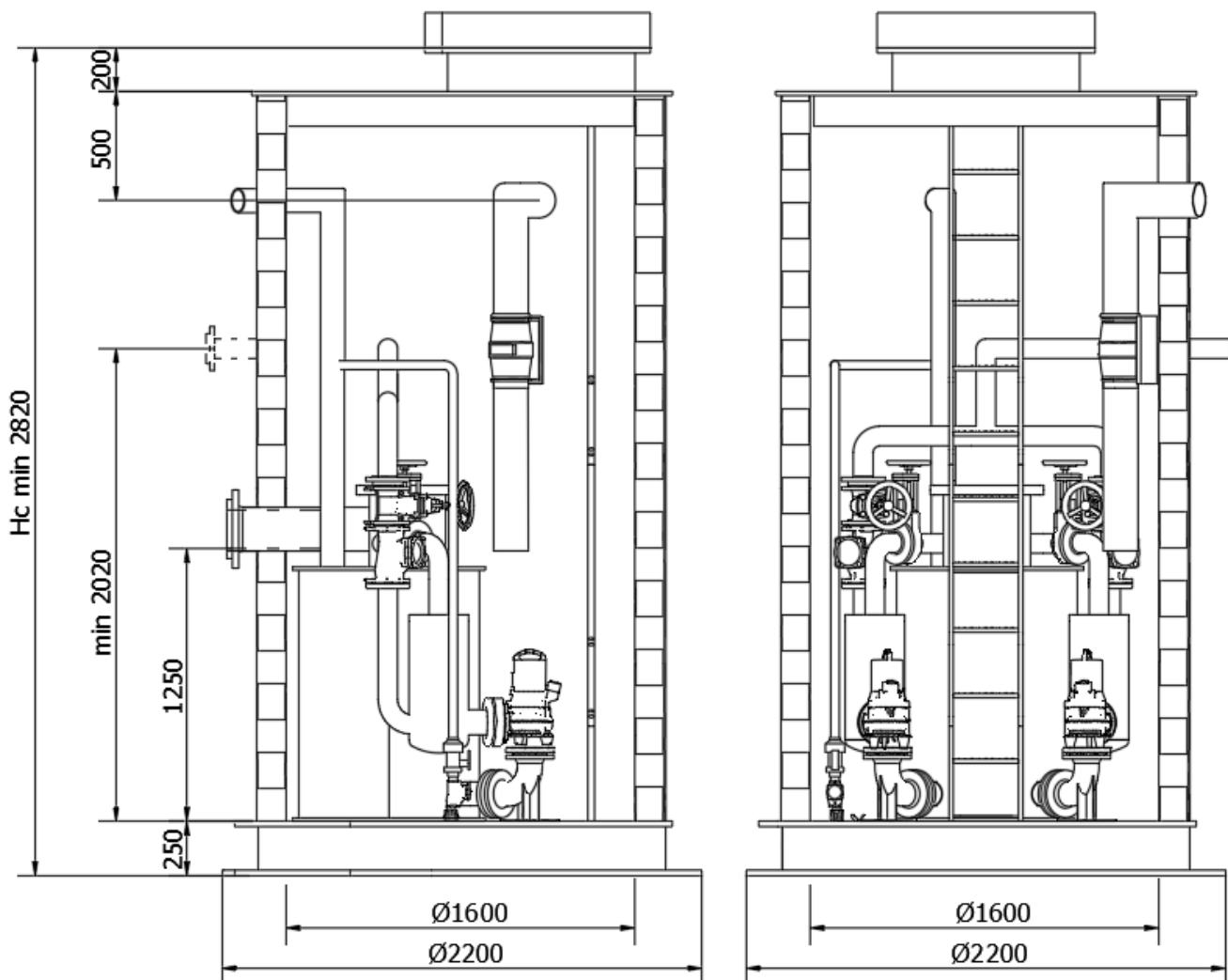
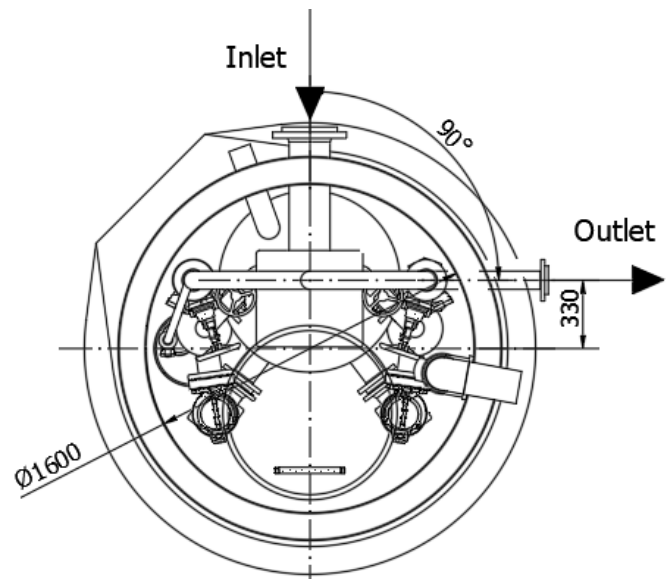

DRY-WELL SEWAGE LIFTING STATION

TYPE: ETS II PE 80/2/1.6/300/P/1600PE

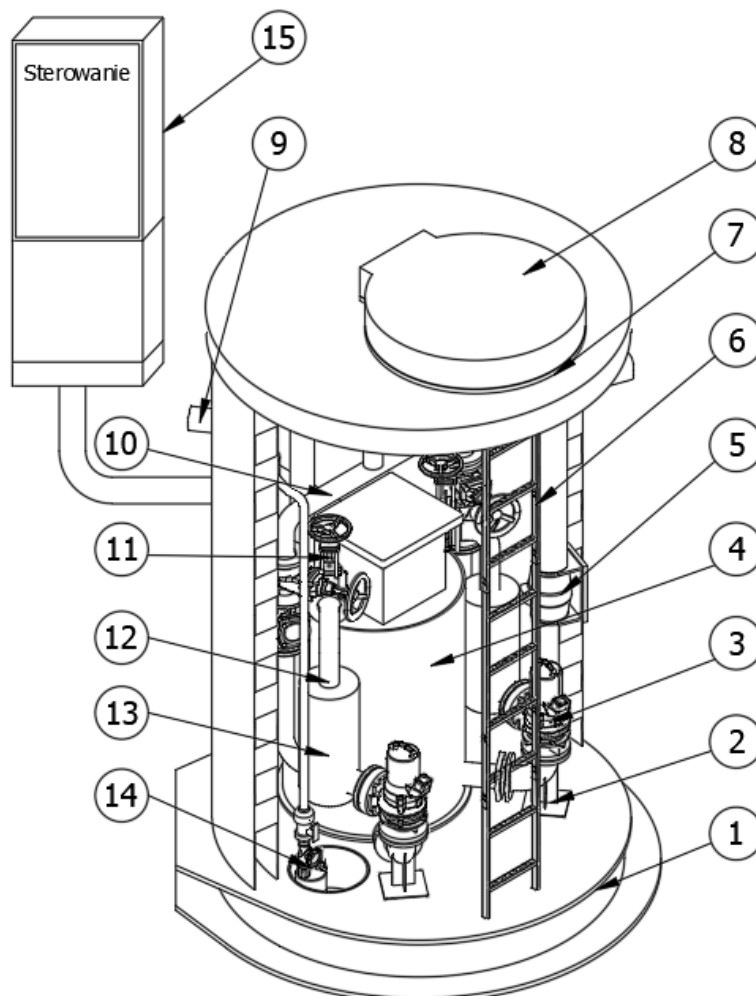

No.	Name	Qty	Material
1	Bottom of the chamber	1	HDPE/Concrete
2	Pump mounting elbow	2	Cast iron/ st. steel 1.4307
3	Pump*	2	Cast iron
4	Retention module	1	HDPE
5	Mechanical ventilation of the chamber	1	HDPE
6	CE marked ladder with a retractable handrail	1	St. steel 1.4301
7	HDPE cover with a manhole chimney	1	HDPE
8	Manhole cover	1	Cast iron/ st. steel 1.4301
9	PE 110 ventilation of the module with an odour neutralizer	1	HDPE/activated carbon
10	Manifold and overflow system	1	HDPE
11	Shut-off gate valve on inlet DN80	1	Cast iron
12	Automatic shut-off system DN80	2	HDPE/St. steel 1.4307
13	Solid particle separator	2	HDPE/St. steel 1.4307
14	Chamber drainage system	1	HDPE/Cast iron
15	Controls	1	

(*) - pumps not included in the standard scope of delivery