

DRY-WELL SEWAGE LIFTING STATION

TYPE: ESS PE 150/2/2.6/1400/P/2600PE



Technical parameters:

- Sump diameter $\varnothing 2600\text{mm}$
- HDPE retention module
- Active retention volume 1400 dm³
- Max inflow $Q_{\text{max}} = 75\text{m}^3/\text{h}$
- Piping diameter DN150
- Inflow connection diameter DN300
- Transport height 3350 mm
- Transport width 3360 mm

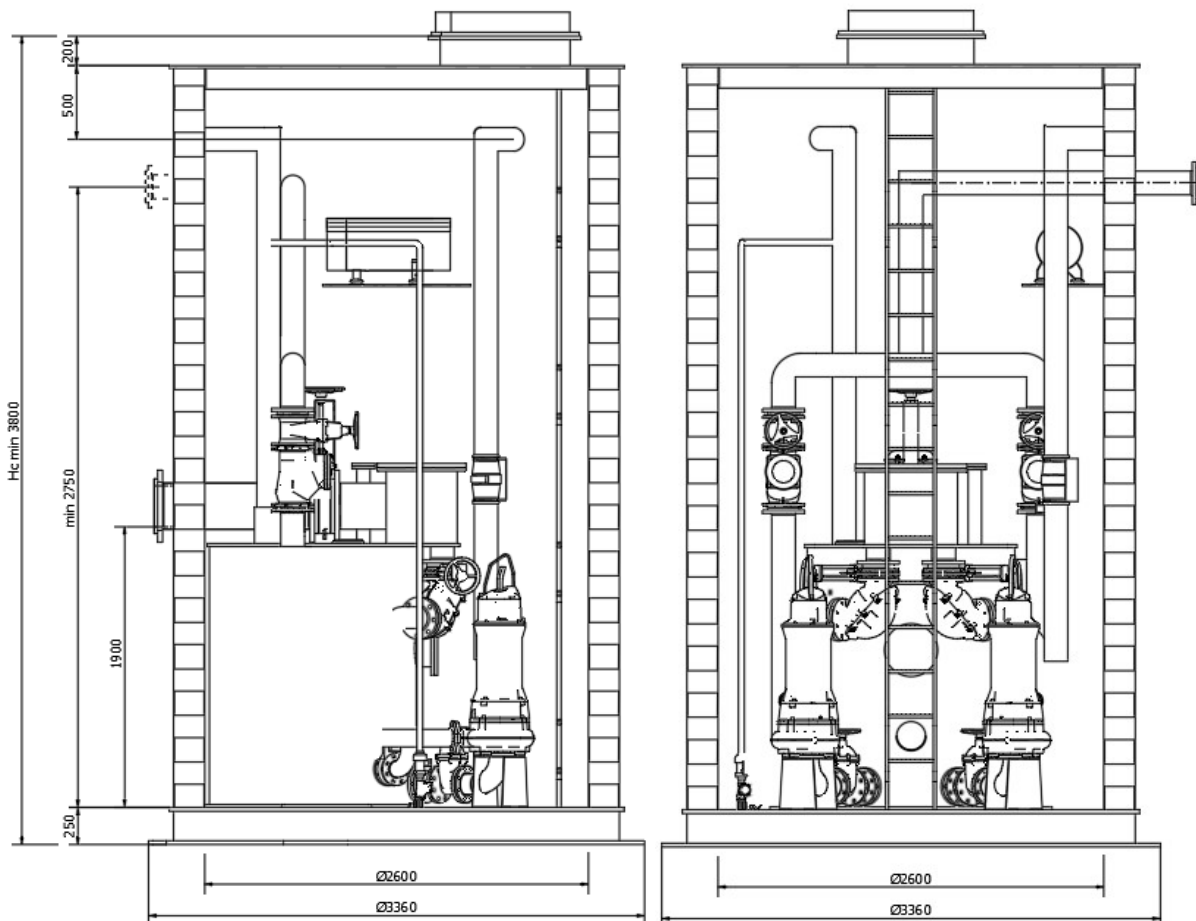
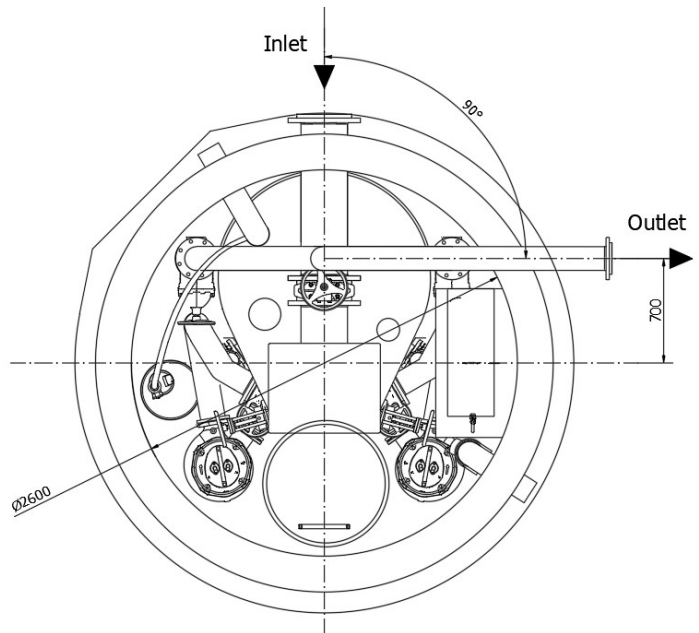

DRY-WELL SEWAGE LIFTING STATION TYPE: ESS PE 150/2/2.6/1400/P/2600PE

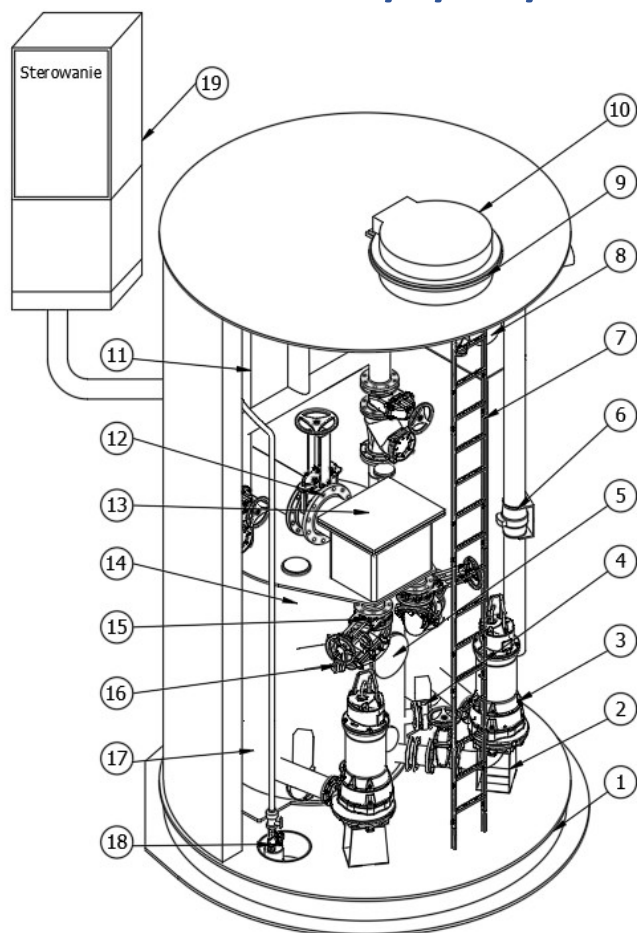

No.	Name	Qty	Material
1	Bottom of the chamber	1	HDPE/Concrete
2	Pump mounting elbow	2	Cast iron/ st. steel 1.4307
3	Pump (*)	2	Cast iron
4	Inflow by-pass	2	HDPE/ st. steel 1.4307/Cast iron
5	Inspection hatch for the retention tank	1	HDPE
6	Mechanical ventilation of the chamber	1	HDPE
7	CE marked ladder with a retractable handrail	1	St. steel 1.4301
8	By-pass power system with an air preparation station	1	HDPE/Steel
9	HDPE cover with a manhole chimney	1	HDPE
10	Manhole cover	1	Cast iron/ st. steel 1.4301
11	PE 160 ventilation of the module with an odour neutralizer	1	HDPE/activated carbon
12	Shut-off gate valve on inlet	1	Cast iron
13	Manifold and overflow system	1	HDPE
14	Retention module	1	HDPE
15	Shut-off valve on the inflow pipeline	2	Cast iron DN150
16	Automatic shut-off system	2	Cast iron DN150
17	Solid particle separator	2	St. steel 1.4307
18	Chamber drainage system	1	HDPE/Cast iron
19	Controls	1	

(*) - pumps not included in the standard scope of delivery