

# DRY-WELL SEWAGE LIFTING STATION MODULE

## TYPE: ESS PE 150/2/2.6/1700 M



### Technical parameters:

- Min. sump diameter  $\varnothing 2600\text{mm}$
- HDPE retention module
- Active retention volume 1700 dm<sup>3</sup>
- Max inflow  $Q_{\text{max}} = 100\text{m}^3/\text{h}$
- Piping diameter DN150
- Inflow connection diameter DN300
- Module weight 1050 kg (\*)

(\*) - without pumps

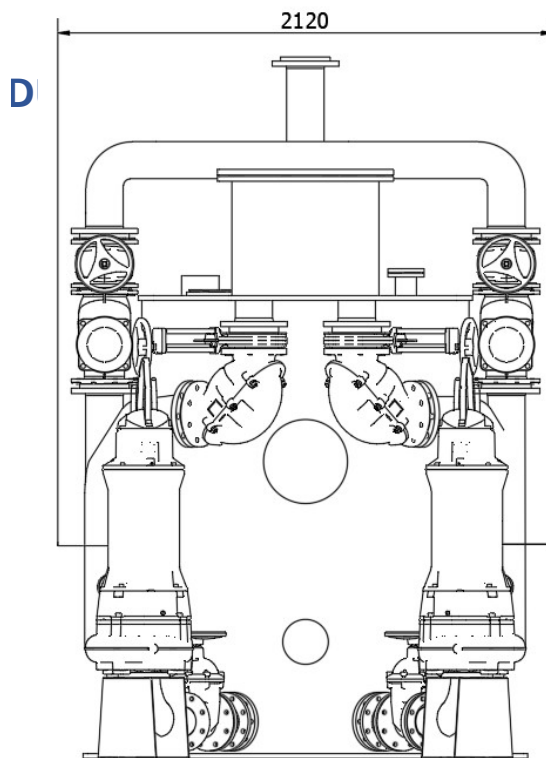
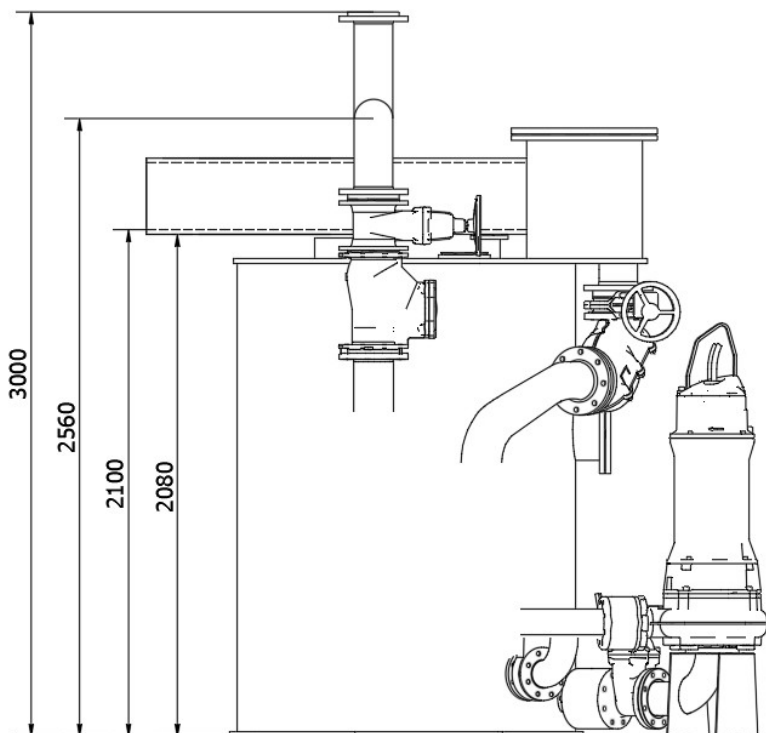
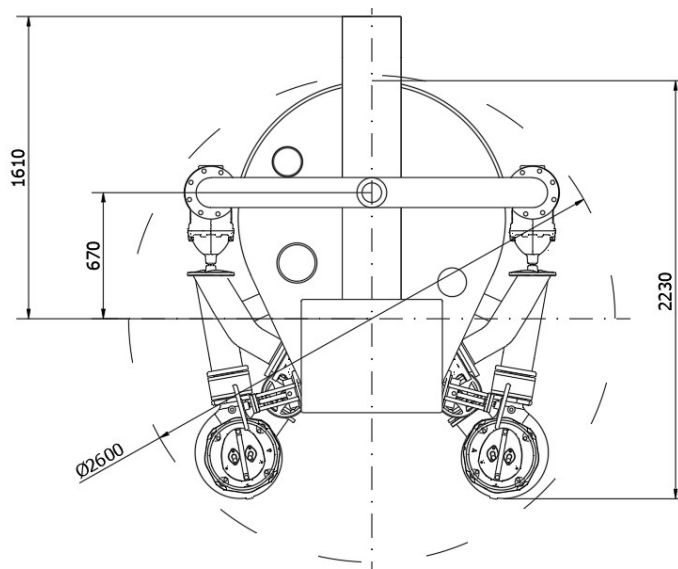

No.	Name
-----	------

<b>1</b>	Pump mounting elbow	2	Cast iron/ st. steel 1.4307
<b>2</b>	Pump (**)	2	Cast iron
<b>3</b>	Retention tank	1	HDPE
<b>4</b>	Inspection hatch for the retention tank	1	HDPE
<b>5</b>	Knife gate valve on inflow DN150	2	Cast iron
<b>6</b>	Hydrostatic probe mount with cable gland	1	HDPE
<b>7</b>	Manifold with overflow system	1	HDPE
<b>8</b>	DN150 module flange connection	1	HDPE/PP
<b>9</b>	Connection pipe for gravity flow (***)	1	HDPE DN315
<b>10</b>	Ventilation of the lifting station module	1	DN150 (HDPE 160)
<b>11</b>	Soft-sealed gate valve on the discharge pipe	2	Cast iron DN150
<b>12</b>	Straight ball check valve on the discharge pipe	2	Cast iron DN150
<b>13</b>	Automatic shut-off of the inflow	2	Cast iron DN150
<b>14</b>	Piping DN150 (PE160/stainless steel DN150)	2	HDPE/st. steel 1.4307
<b>15</b>	Solids separator	2	St. steel 1.4307
<b>16</b>	Soft-sealed gate valve	2	Cast iron
<b>17</b>	By-pass system	2	HDPE/st.steei 1.4307/cast iron

(\*\*) - pumps not included in the standard scope of delivery

(\*\*\*) - pipe terminated with a flange connection 350 mm downstream of the manifold