

DRY-WELL SEWAGE LIFTING STATION MODULE

TYPE: ETS II PE 100/2/2.0/500 M



Technical parameters:

- Min. sump diameter $\varnothing 2000\text{mm}$ (*)
- HDPE retention module
- Active retention volume 500 dm³
- Max inflow $Q_{\text{max}} = 30\text{m}^3/\text{h}$
- Piping diameter DN100
- Inflow connection diameter DN250
- Module weight 700 kg (**)

(*) - for pumps with higher lifting height min. diameter 2500 or 2600

(**) - without pumps

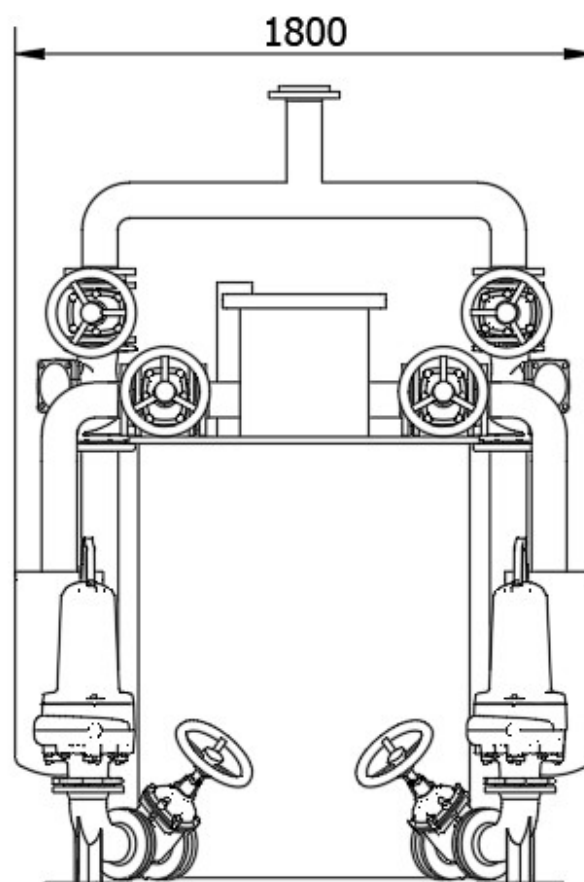
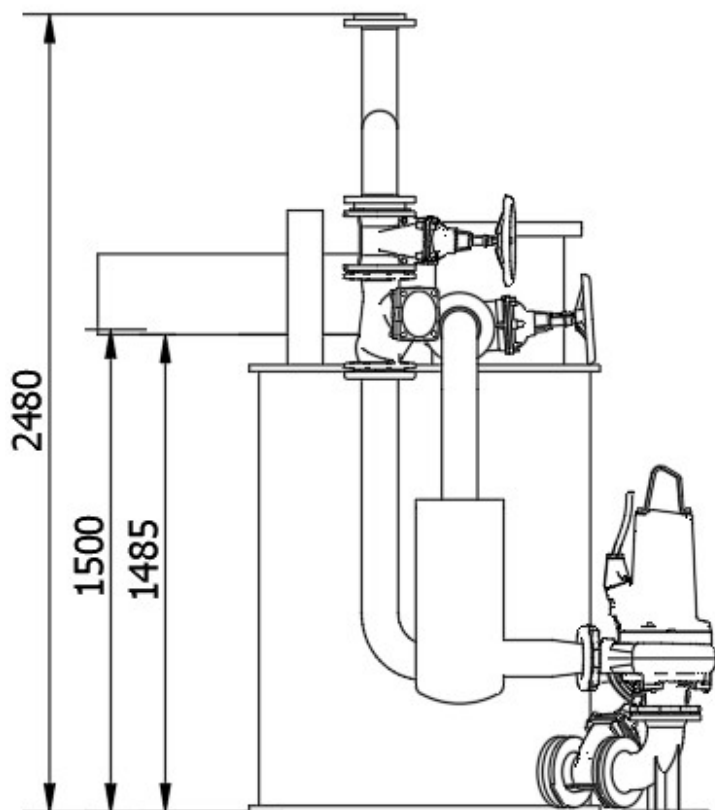
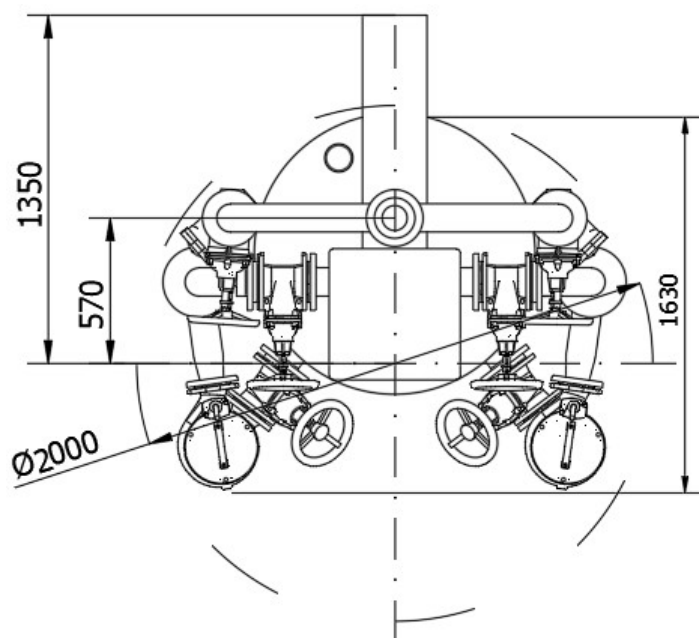



DRY-WELL SEWAGE LIFTING STATION MODULE TYPE: ETS PE II 100/2/2.0/500 M

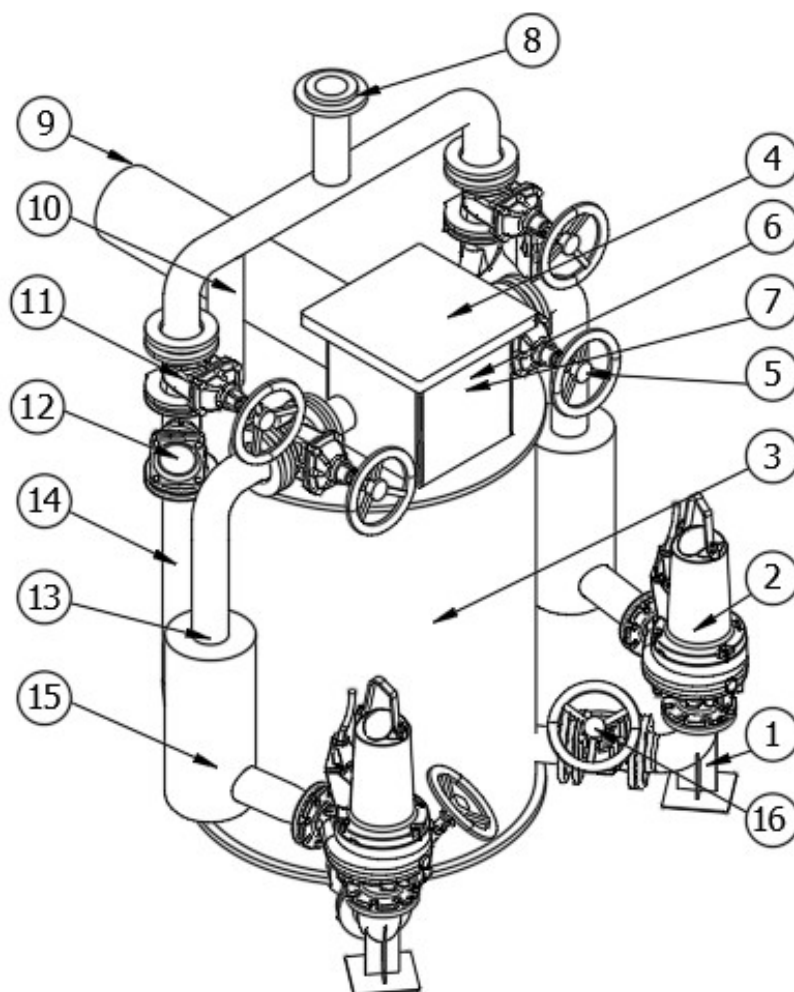

| No. | Name | Qty | Material |
|-----|--|-----|-----------------------------|
| 1 | Pump mounting elbow | 2 | Cast iron/ st. steel 1.4307 |
| 2 | Pump (***) | 2 | Cast iron |
| 3 | Retention tank | 1 | HDPE |
| 4 | Inspection hatch for the retention tank | 1 | HDPE |
| 5 | Soft-sealed gate valve on inflow DN100 | 2 | Cast iron |
| 6 | Hydrostatic probe mount with cable gland | 1 | HDPE |
| 7 | Manifold with overflow system | 1 | HDPE |
| 8 | DN100 module flange connection | 1 | HDPE/PP |
| 9 | Connection pipe for gravity flow DN250 | 1 | HDPE |
| 10 | Ventilation of the lifting station module DN100 (HDPE 110) | 1 | HDPE |
| 11 | Soft-sealed gate valve on the discharge pipe DN100 | 2 | Cast iron |
| 12 | Straight ball check valve on the discharge pipe DN100 | 2 | Cast iron |
| 13 | Automatic shut-off of the inflow DN100 | 2 | HDPE/st. steel 1.4307 |
| 14 | Piping DN100 (PE110/stainless steel DN100) | 2 | HDPE/st. steel 1.4307 |
| 15 | Solids separator | 2 | St. steel 1.4307 |
| 16 | Soft-sealed gate valve | 2 | Cast iron |

(***) - pumps not included in the standard scope of delivery