

DRY-WELL SEWAGE LIFTING STATION

TYPE: ETS II PE 100/2/2.0/500/P/2000PE



Technical parameters:

- Sump diameter $\varnothing 2000\text{mm}$ (*)
- HDPE retention module
- Active retention volume 500 dm³
- Max inflow $Q_{\text{max}} = 30\text{m}^3/\text{h}$
- Piping diameter DN100
- Inflow connection diameter DN250
- Transport height 2690 mm
- Transport width 2450 mm

(*) - for pumps with higher lifting height min. diameter 2600

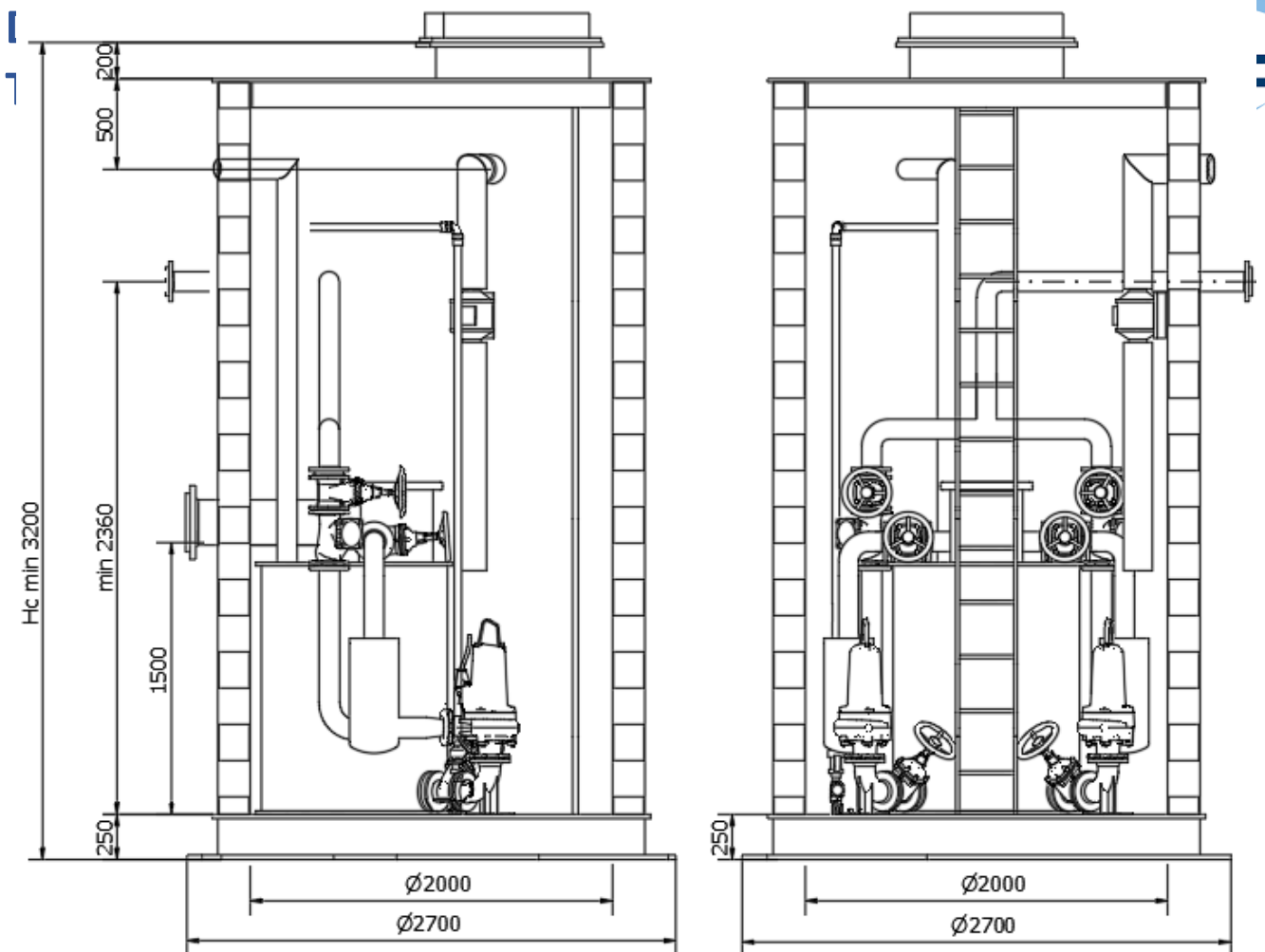
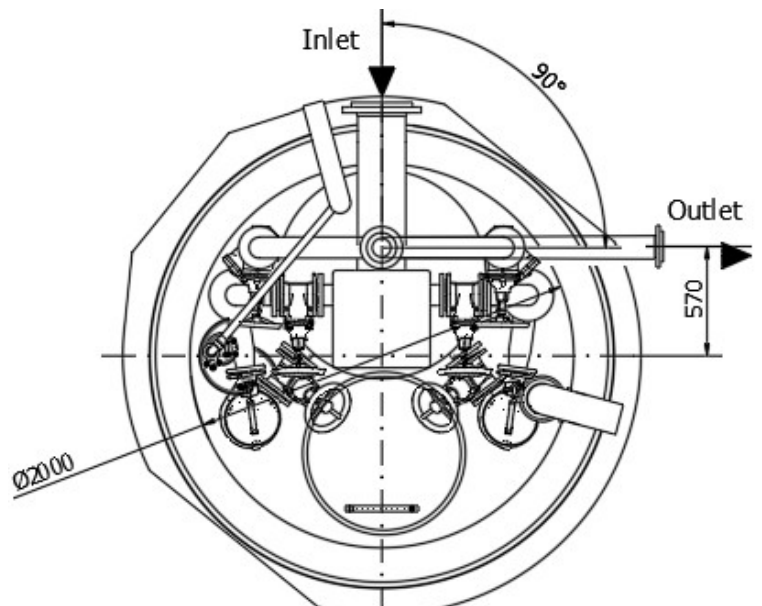

No.	Name	Qty	Material
-----	------	-----	----------

1	Bottom of the chamber	1	HDPE/Concrete
2	Pump mounting elbow	2	Cast iron/ st. steel 1.4307
3	Pump (**)	2	Cast iron
4	Retention module	1	HDPE
5	CE marked ladder with a retractable handrail	1	St. steel 1.4301
6	Mechanical ventilation of the chamber	1	HDPE
7	HDPE cover with a manhole chimney	1	HDPE
8	Manhole cover	1	Cast iron/ st. steel 1.4301
9	PE 110 ventilation of the module with an odour neutralizer	1	HDPE/activated carbon
10	Manifold and overflow system	1	HDPE
11	Shut-off gate valve on inlet DN100	2	Cast iron
12	Automatic shut-off system DN100	2	HDPE/St. steel 1.4307
13	Solid particle separator	2	HDPE/St. steel 1.4307
14	Chamber drainage system	1	HDPE/Cast iron
15	Controls	1	

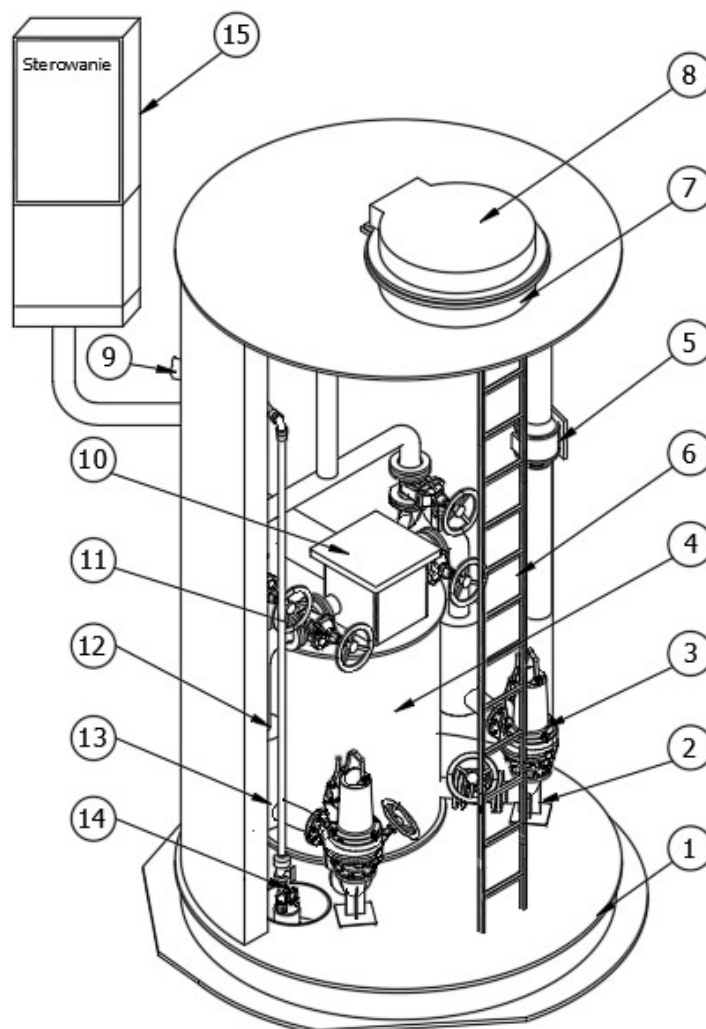

(*) - pumps not included in the standard scope of delivery