

# High-efficiency lamella separators with settling tank ESL-ZH

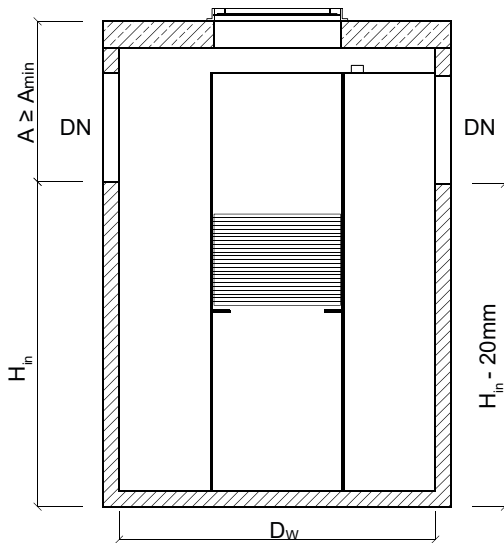

The technical specifications of each device series with technical description and possible modifications of the dimensions can be found at [www.ecol-unicon.com](http://www.ecol-unicon.com)

ESL-ZH separators were tested for nominal and maximum flows and the results of the tests were confirmed by the Building Research Institute by issuing the National Technical Assessment ITB-KOT2017/0212 edition 3. ESLZH separators represent class I (according to EN 858-1), it also obtained CE mark allowing to be applied in all EU countries.

The chamber is made in accordance with Norm EN 1917 or National Technical Assessment ITB, concrete of class at least C35/45 waterproof  $\geq W8$ , with water absorption lower than 5%, frost resistant F150 in the water and F50 in 2% NaCl, stable for petroleum products in accordance with EN 858-1.



Model $Q_{nom}/Q_{max}/V_{os}^*$	$Q_{nom}^*$ (NS)	$Q_{max}^*$	$D_w$	$H_w$	$A_{min}^{**}$	Diameter of inlet/ outlet pipes DN	Actual capacity of sedimentary section	Oil storage volume	Weight of the heaviest element	Total weight ***
	[dm <sup>3</sup> /s]	[dm <sup>3</sup> /s]								
ESI -ZH 1,5/15/150	1,5	15	1200	1220	830	max 400	150	90	2900	3700
ESI -ZH 1,5/15/300	1,5	15	1200	1540	1010	max 400	600	90	3700	4500
ESI -ZH 1,5/15/450	1,5	15	1200	1540	1010	max 400	600	90	3700	4500
ESI -ZH 3/30/300	3	30	1200	1540	1010	max 400	600	90	3700	4500
ESI -ZH 3/30/600	3	30	1200	1540	1010	max 400	600	90	3700	4500
ESI -ZH 3/30/900	3	30	1500	1750	850	max 400	1200	150	5600	6900
ESI -ZH 6/60/600	6	60	1200	1540	1010	max 400	600	90	3700	4500
ESI -ZH 6/60/1200	6	60	1500	1750	850	max 400	1200	150	5600	6900
ESI -ZH 6/60/1800	6	60	2000	2000	820	max 600	2000	300	7700	9700
ESI -ZH 10/100/1000	10	100	1500	1750	850	max 400	1200	150	5600	6900
ESI -ZH 10/100/2000	10	100	2000	2000	820	max 600	2000	300	7700	9700
ESI -ZH 10/100/3000 S	10	100	2000	2670	900	max 600	4000	300	5800	11600
ESI -ZH 15/150/1500	15	150	2000	2000	820	max 600	2000	300	7700	9700
ESI -ZH 15/150/3000 S	15	150	2000	2670	900	max 600	4000	300	5800	11600
ESI -ZH 15/150/4500 S	15	150	2000	2670	900	max 600	4500	225	5800	11600
ESI -ZH 20/200/2000	20	200	2000	2000	820	max 600	2000	300	7700	9700
ESI -ZH 20/200/4000 S	20	200	2000	2670	900	max 600	4000	300	5800	11600
ESI -ZH 20/200/6000 S (DN2000)	20	200	2000	3340	980	max 600	6000	300	7600	13400
ESI -ZH 20/200/6000 S (DN2500)	20	200	2500	2600	970	max 800	6000	300	6700	16500
ESI -ZH 30/300/3000 S	30	300	2000	2560	1010	max 800	4000	600	5800	11200
ESI -ZH 30/300/6000 S	30	300	2500	3240	1330	max 800	8000	1200	6700	18700
ESI -ZH 30/300/9000 S	30	300	3000	3080	1520	max 1200	10000	1500	7400	24200
ESI -ZH 40/400/4000 S	40	400	2000	2560	1010	max 800	4000	600	5800	11200
ESI -ZH 40/400/8000 S	40	400	2500	3240	1330	max 800	8000	1200	6700	18700
ESI -ZH 40/400/12000 S	40	400	4600	2600	1950	max 1200	20000	1500	12400	52100
ESI -ZH 50/500/5000 S	50	500	2500	3240	1330	max 800	8000	1200	6700	18700
ESI -ZH 50/500/10000 S	50	500	3000	3080	1520	max 1200	10000	1500	7400	24200
ESI -ZH 50/500/15000 S	50	500	4600	2600	1950	max 1200	20000	1500	12400	52100
ESI -ZH 60/600/6000 S	60	600	2500	3240	1330	max 800	8000	1200	6700	18700
ESI -ZH 60/600/12000 S	60	600	4600	2600	1950	max 1200	20000	1500	12400	52100
ESI -ZH 65/650/6500 S	65	650	2500	3240	1330	max 800	8000	1200	6700	18700
ESI -ZH 65/650/13000 S	65	650	4600	2600	1950	max 1200	20000	1500	12400	52100
ESI -ZH 70/700/7000 S	70	700	2500	3240	1330	max 800	8000	1200	6700	18700
ESI -ZH 70/700/14000 S	70	700	4600	2600	1950	max 1200	20000	1500	12400	52100
ESI -ZH 75/750/7500 S	75	750	2500	3240	1330	max 800	8000	1200	6700	18700
ESI -ZH 75/750/15000 S	75	750	4600	2600	1950	max 1200	20000	1500	12400	52100
ESI -ZH 80/800/8000 S	80	800	2500	3240	1330	max 800	8000	1200	6700	18700
ESI -ZH 80/800/16000 S	80	800	4600	2600	1950	max 1200	20000	1500	12400	52100
ESI -ZH 90/900/9000 S	90	900	3000	3080	1520	max 1200	10000	1500	7400	24200
ESI -ZH 90/900/18000 S	90	900	4600	2600	1950	max 1200	20000	1500	12400	52100
ESI -ZH 100/1000/10000 S	100	1000	3000	3080	1520	max 1200	10000	1500	7400	24200
ESI -ZH 100/1000/20000 S	100	1000	4600	2600	1950	max 1200	20000	1500	12400	52100

\*)  $Q_{nom}$  [dm<sup>3</sup>/s] (NS) – nominal flow value for which > 99% impurities is stopped (value obtained during the tests according to norm EN 858-1).  
 $Q_{max}$  [dm<sup>3</sup>/s] – maximum hydraulic flow capacity of the device, at which there is no danger of flushing out accumulated dirt.

\*\*) Increasing the A value through the use of additional superstructure rings

\*\*\*) The weights indicated apply to devices without additional superstructure rings; for devices delivered to the construction site in parts (S), the weight does not include the tonnage of technological equipment. The final weight will be determined before delivery of the device.

S - devices delivered to the construction site in the elements.

Ecol-Unicon Company reserves the right to implement changes in equipment design without prior notice.

The separator can be designed according to individual customer needs. Larger models are available upon individual request.

Technical consultations: [export@ecol-unicon.com](mailto:export@ecol-unicon.com)

